

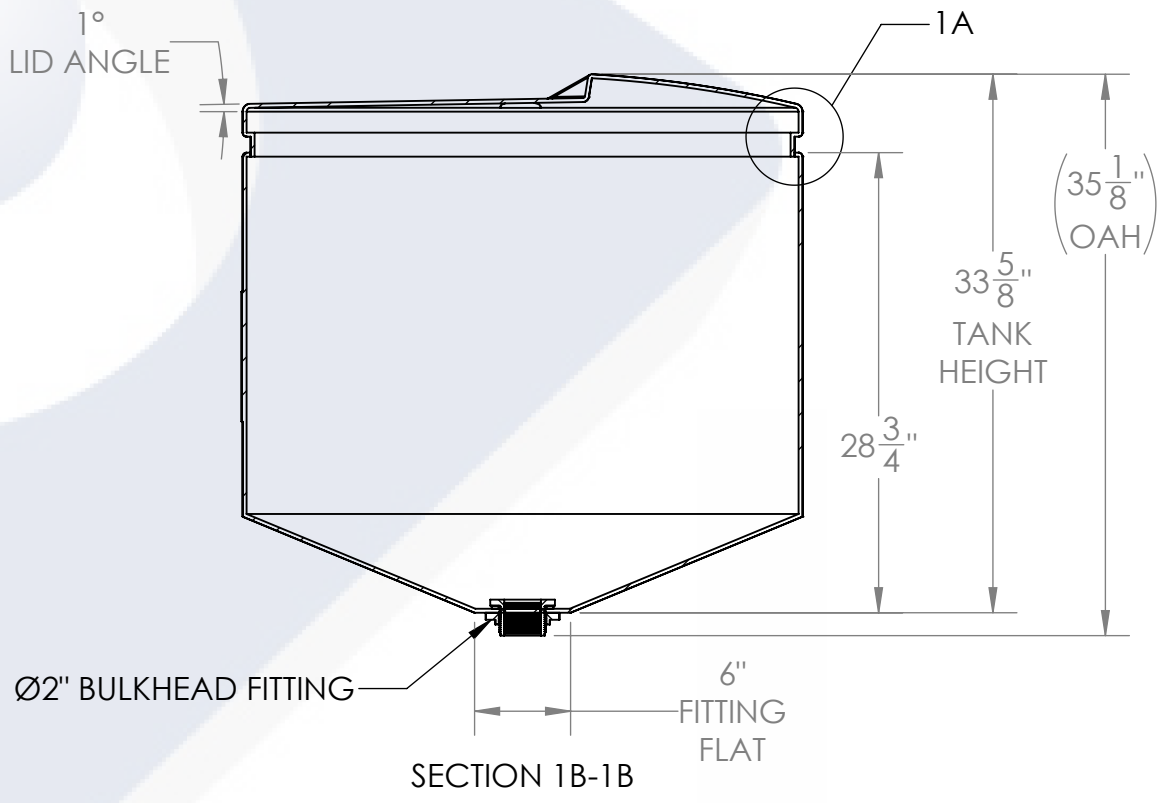

**ISOMETRIC VIEW
(FRONT)**

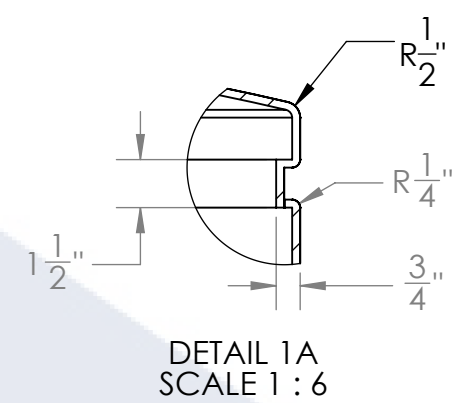
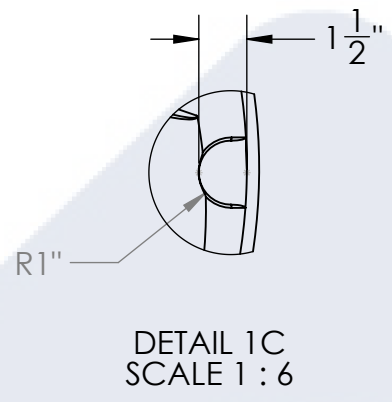
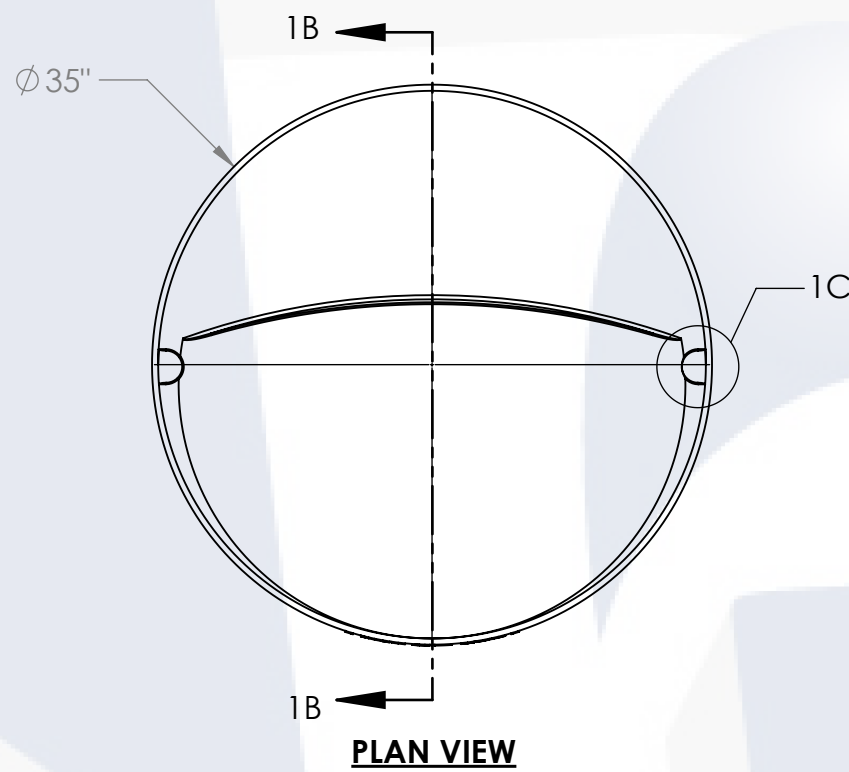

- NOTES:**
1. CAPACITY: 100 GAL. NOMINAL
 2. TANK MATERIAL: XLPE
 3. SERVICE PRESSURE: ATMOSPHERIC
 4. NSF/ANSI STANDARD 61 CERTIFIED

PROPRIETARY AND CONFIDENTIAL
THE INFORMATION CONTAINED IN THIS DRAWING IS THE SOLE PROPERTY OF PEABODY ENGINEERING. ANY REPRODUCTION IN PART OR AS A WHOLE WITHOUT THE WRITTEN PERMISSION OF PEABODY ENGINEERING IS PROHIBITED.

UNLESS OTHERWISE SPECIFIED:		NAME	DATE	
DIMENSIONS ARE IN INCHES TOLERANCES: ±1/4" ANGULAR: ±.5° ONE PLACE DECIMAL: ±.25 TWO PLACE DECIMAL: ±.125 THREE PLACE DECIMAL: ±.063		DRAWN	SMF 02/01/23	
TANK MATERIAL: HDPE	INNER TANK S/N:	CHECKED		PROJECT: CONE BOTTOM TANKS
OUTER TANK S/N:	CUSTOMER PO#	ENG APPR.		CUSTOMER: PEABODY STANDARD
DO NOT SCALE DRAWING		MFG APPR.		SITE/LOCATION: -
		Q.A.		PART NUMBER: -
				SIZE B DESC. 100GAL CONE BOTTOM TANK REV. A
				SCALE: 1:12 SHEET 1 OF 1